

# SSI Technologies - Application Note AT-AN5

## Acu-Trac™ Ultrasonic Level Sensors

### RS-485 Mode Messaging

#### General

SSI's Acu-Trac™ ultrasonic level sensors broadcast and receive commands over a standard TIA/EIA RS-485 serial data bus enabling the sensors to communicate and share data with other modules located on the data link.

The RS-485 data link is a serial data link meaning that messages are transmitted one bit at time in sequence until the entire message has been completed. Idle states, I.E. the down time in-between messages is used to signal the bus availability to other transmitting nodes within the network.

The Acu-Trac™ ultrasonic level sensor is designed to communicate at a rate of 9600 baud. During normal operation, the Acu-Trac™ ultrasonic level sensor will broadcast a 19 byte volume measurement message every 0.50 seconds consuming approximately 4% of the available data link bandwidth.

For illustration purposes, all the message drawings depicted herein are referenced from the transmitting nodes perspective with the beginning of the message located on the drawing's right hand side and the message end located on the drawing's left.

#### Message & Character Construction

Messages are formatted into a series of characters, 10 bits each, which are strung together to create a complete message as shown in the *RS-485 Message Construction* drawing below.

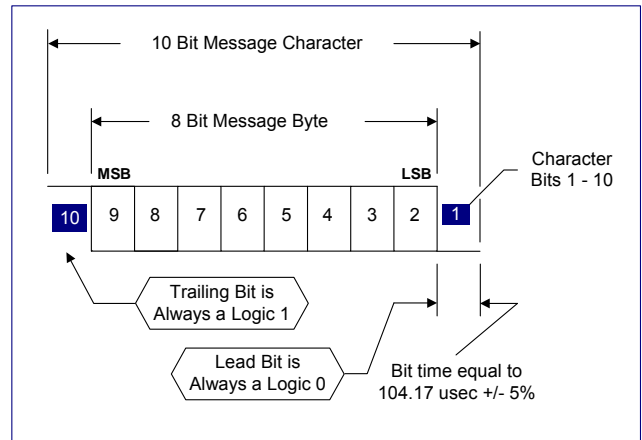

**Character Definitions**

Each character within the message string is comprised of a leading bit, or start bit, an 8 bit message byte followed by the trailing bit or stop bit. The start bit is always at a logic low level (0), while the trailing bit is always at a logic high level (1). The message byte is transmitted with the LSB, least significant bit, first followed in sequence with bits 2, 3, 4 and so on. See the above drawing titled *Character Definitions*.

The bit time for each character bit is 104.17 μsecs +/- 0.5% which effectively yields a baud rate of 9600 bits per second.

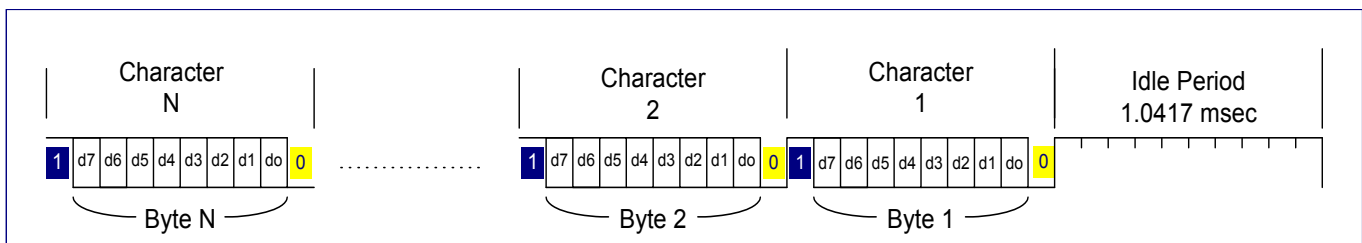

**RS-485 Message Construction**



# SSI Technologies - Application Note AT-AN5

## Acu-Trac™ Ultrasonic Level Sensors

### RS-485 Mode Messaging

#### Idle State

The bus will return to a logic level high (1) when all of the data link transmitters are turned off as measured at the input to the bus receiver(s); this is called the idle state.

As mentioned previously, the idle state in-between messages serves as a delimiter on the RS-485 bus. Any transmitting node on the bus must first verify that this idle state has existed for at least 10 bit times or 1.0417 msecs before initiating a new message transmission.

A receiving node that has lost synchronization and cannot distinguish between the message stop bit and any other message high bit, can use the idle period to reestablish synchronization.

Re-synchronization is achieved by noting the receipt of 12 consecutive high logic bits. In the absence of errors, the first logic 0 following the receipt of 12 consecutive high bits is the start bit of the next message.

#### SSI Message Format

All messages transmitted and received by the Acu-Trac™ ultrasonic level sensor family follow the format depicted on the bottom of this page and described herein.

The first message byte, Message Transmitter Identification, is always the identification number of the device broadcasting the message. The Acu-Trac™ ultrasonic level sensor uses 143 for its identification number and communicates with and responds to commands from transceiver node identification number(s)  $\geq 128$ . (We use 177 in our example)

The second message byte, Service Code, is always 254 for Acu-Trac™ ultrasonic level sensor messages.

The third message byte, Message Receipt Identifier, provides the identification number for the intended message recipient. The Acu-Trac™ ultrasonic level sensor will only respond to commands in which the third byte, Message Receipt Identifier, is set to 143 designating the identification number for the Acu-Trac™ ultrasonic level sensor family.

The fourth message byte defines the Number of Remaining Characters in the message exclusive of the checksum. If the fourth byte is a one (1) then the message is a command and contains no data. If the fourth byte is greater than 1 then the sixth message byte will contain the number of data elements in the transmission.

The fifth message byte, Message Identifier, defines what the message is and/or is intended to accomplish. ACU-TRAC's™ ultrasonic level sensor family responds to the following message identifiers:

The Acu-Trac™ ultrasonic level sensor will use the following message identifiers in its transmissions:

<u>Identifier</u>	<u>Message</u>
190	Measurement Broadcast
193	Programming/Diagnostic Data Broadcast

The ultrasonic level sensor will also respond to the following message identifiers used as commands.

<u>Identifier</u>	<u>Message</u>
192	Programming Command
213	Diagnostic Command



# SSI Technologies - Application Note AT-AN5

## Acu-Trac™ Ultrasonic Level Sensors

### RS-485 Mode Messaging

The sixth message byte, Number of Data Characters, denotes the number of data elements contained which are to follow and is only used in messages which contain data.

Bytes 7 through N-1, Data, are reserved for data characters.

The last message byte, Checksum, is the two's complement check sum for the entire message exclusive of the checksum and is used to qualify the validity of the message. A simple error detection scheme may be implemented by adding the checksum to the sum of all of the message characters; the 8 bit sum should be zero neglecting any carry(s) generated.

### Message Example

The following example describes the process for decoding the ultrasonic level sensor's volume message and how that message would look out on the RS485 bus. A graphical depiction of the message is shown on the next page titled *Volume Measurement Message Example*. In this example, the received message is as follows:

Byte1	Byte 2	Byte3	Byte4	Byte 5	Byte 6	Byte 7
<b>143</b>	<b>254</b>	<b>177</b>	<b>14</b>	<b>190</b>	<b>12</b>	<b>1</b>
Byte 8	Byte 9	Byte10	Byte11	Byte12	Byte13	Byte14
<b>64</b>	<b>1</b>	<b>224</b>	<b>48</b>	<b>48</b>	<b>48</b>	<b>51</b>
Byte15	Byte16	Byte17	Byte18	Byte19		
<b>51</b>	<b>50</b>	<b>55</b>	<b>53</b>	<b>52</b>		

The 1<sup>st</sup> received byte, Message Transmitter Identification, value 143, is the originator of the broadcast, meaning that the message was transmitted by an Acu-Trac® ultrasonic level sensor.

The 2<sup>nd</sup> byte, Service Code, value 254, is the proprietary service code designation used by SSI for all Acu-Trac® ultrasonic level sensor messages.

The 3<sup>rd</sup> byte, Message Receipt Identifier, value 177, denotes the intended recipient for the broadcast which is always a transceiver node number ≥ 128.

The 4<sup>th</sup> byte, Number of Remaining Characters, value 14, is the number of characters remaining in the message.

The 5<sup>th</sup> byte, Message Identifier, value 190, is the message identifier meaning that the message is a Measurement Broadcast.

The 6<sup>th</sup> byte, Number of Data Characters, value 12, is the number of data bytes in the message.

The 7<sup>th</sup> byte, Data, value 1, is the MSB of % of full scale capacity value.

The 8<sup>th</sup> byte, Data, value 64, is the LSB of the % of capacity value. Therefore the target location as a % of full scale capacity can now be calculated as follows:

$$\% \text{ of Capacity} = (\text{MSB} \times 256 + \text{LSB})/800$$

$$\% \text{ of capacity} = (1 \times 256 + 64)/800$$

$$\% \text{ of Capacity} = 40.0\%$$

The 9<sup>th</sup> byte, Data, value 1, is the MSB of the measurement. Based on the sensor's pre programmed unit scale.

The 10<sup>th</sup> byte, Data, value 224, is the LSB of the measurement, based on the sensor's preprogrammed unit scale.



# SSI Technologies - Application Note AT-AN5

## Acu-Trac™ Ultrasonic Level Sensors

### RS-485 Mode Messaging

The 11<sup>th</sup> byte, Data, value 48, is an ASCII representation of the most significant digit of the serial number which is 0.

The 12<sup>th</sup> byte, Data, value 48, is an ASCII representation of the next digit of the serial number which is 0.

The 13<sup>th</sup> byte, Data, value 48, is an ASCII representation of the next digit of the serial number which is 0.

The 14<sup>th</sup> byte, Data, value 51, is an ASCII representation of the next digit in the serial number which is 3.

The 15<sup>th</sup> byte, Data, value 51, is an ASCII representation of the next digit of the serial number which is 3.

The 16<sup>th</sup> byte, Data, value 50, is an ASCII representation of the next digit of the serial number which is 2.

The 17<sup>th</sup> byte, Data, value 55, is an ASCII representation of the next digit in the serial number which is 7.

The 18<sup>th</sup> byte, Data value, 53, is an ASCII representation of the least significant digit in the serial number which is 5.

Based on received message bytes 11 through 18 we can now assemble the serial number as follows:

Byte11	Byte12	Byte13	Byte14	Byte15	Byte16	Byte17
0	0	0	3	3	2	7
Byte18						
5						

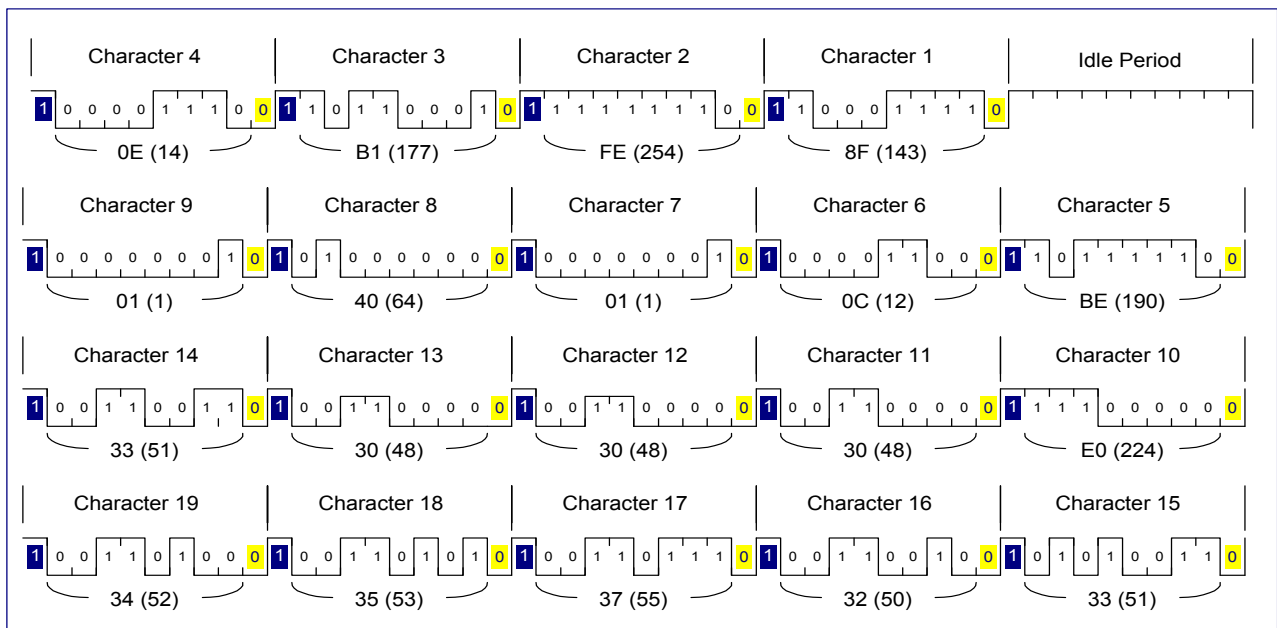

**Distance Measurement Message Example**



# SSI Technologies - Application Note AT-AN5

## Acu-Trac™ Ultrasonic Level Sensors

### RS-485 Mode Messaging

Serial number = 00033275

Knowing the serial number allows one to look up the sensor's operating mode and full scale range using a cross referenced table of values linked to the sensor's serial number.

For the purposes of this example we are using an Acu-Trac™ ultrasonic level sensor with a full scale range of 30 inches operating in the rectilinear mode. To summarize:

Sensor serial: 00033275  
Operating Mode: Rectilinear  
Full Scale range: 150 gallons

Based on this data, we can now determine the actual volume in the tank using the measurement LSB, value 01, and MSB, value 224, contained within message bytes 9 and 10. The volume in the tank can be derived as follows:

Volume = (MSB x 256 + LSB)/8  
Volume = (1x256 +224)/8 gallons  
Volume = 60.0 gallons

The last byte in the message is the Checksum, value 52 or in hex 0x34. The checksum provides a convenient method for checking the validity of the message by using the two's compliment sum of all of the data characters ignoring any carries generated along the way. For example:

Calculate the Sum of all the message bytes, Bytes1 through 19 = 1536  
Convert 1536 to Hexadecimal = 0x600  
Ignore the carries using only the least significant byte = 0x00 or 0 decimal

The result from the calculation was 0 meaning that the message was correctly received.

To summarize we can conclude from this message that the tank fitted with Ultrasonic level sensor serial number 00033275 has 60 gallons left.

### Transceiver Electrical Characteristics

The following electrical characteristics and conventions refer to the Serial Bus Node Diagram located on the next page.

Positive logic is used when referring to the state of transmitted inputs and receiver outputs. The bus is considered to be at a logic high (1) state if the A line is at least 0.2 volts more positive than the B line. Conversely the bus is considered to be at a logic low (0) state whenever the A line is 0.2 volts below that of the B line. The transceiver circuit utilizes a standard RS-485 transceiver connected to drive the differential data bus into the logic low (0) state. The logic high state is controlled by the 4.7 k-ohm pull up resistor and the 4.7 k-ohm pull down resistors.

EMI suppression is facilitated by the 1nf capacitor in conjunction with the 47 ohm series resistor located on each line.



# SSI Technologies - Application Note AT-AN5

## Acu-Trac™ Ultrasonic Level Sensors

### RS-485 Mode Messaging

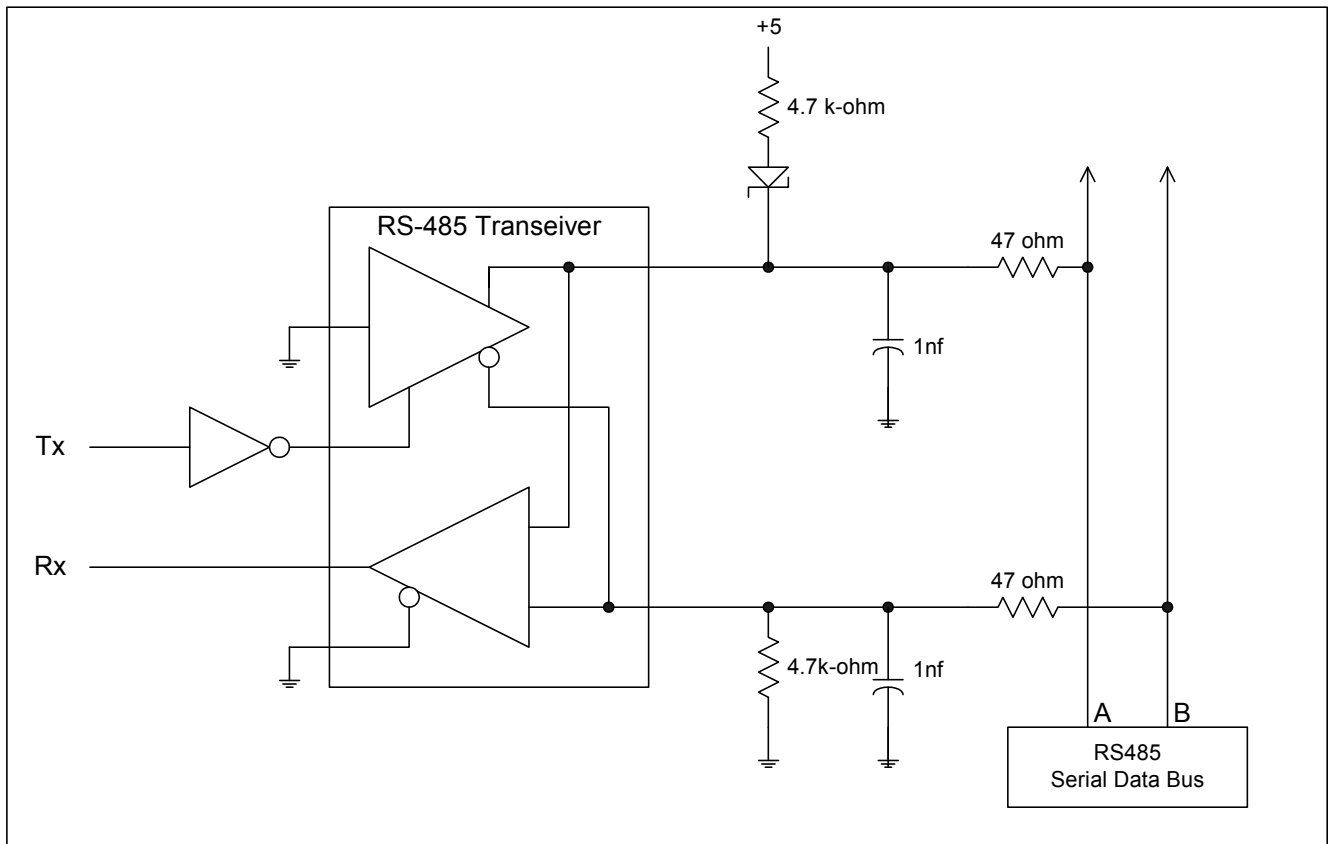

**Serial Bus Node Diagram**

# SSI Technologies - Application Note AT-AN5

## Acu-Trac™ Ultrasonic Level Sensors

### RS-485 Mode Messaging

#### RS-485 Messages

The Acu-Trac™ ultrasonic level sensors broadcast and receive commands over the RS-485 serial data link enabling the sensors to communicate to and share data with other modules located on the bus.

The ultrasonic level sensor messages can be loosely organized as follows:

- 1) Setup & Programming Commands
- 2) Timed Broadcasts

The Setup & Programming Commands are used to program the ultrasonic level sensor for the particular tank's size shape and installation.

Note: These commands can only be issued and responded to with one sensor enabled on the data link.

The Timed Broadcasts convey measurement data from the ultrasonic level sensor(s) to other modules on the bus. Each sensor consumes approximately 5% of the available 9600 baud bus capacity and, thus, up to 10 sensors may be connected on to a single bus.



# SSI Technologies - Application Note AT-AN5

## Acu-Trac™ Ultrasonic Level Sensors

### RS-485 Mode Messaging

#### Setup & Programming Commands

<b>Analog Gauge Drive Transfer Function Parameters</b>	Read Command	MID	254	143	3	192	1	130	chk				
	Write Command	MID	254	143	11	192	9	130	D1	D2	---	D8	chk
	Response	143	254	MID	11	192	9	130	D1	D2	---	D8	chk

Where

MID 8 bit transmitting station identification number, must be 128 or greater.  
 D1 D2 16 bit DAC Output Voltage @ Capacity Maximum Limit @ 10.04 mv per bit,  
 D3 D4 16 bit DAC Output Voltage @ Capacity Minimum Limit @ 10.04 mv per bit  
 D5 D6 16 bit Capacity Maximum Limit 0.125% per bit, (msb first lsb last)  
 D7 D8 16 bit Capacity Minimum Limit 0.125% per bit, (msb first lsb last)

<b>Measurement Filter Timer Constant</b>	Read Command	MID	254	143	3	192	1	131	chk			
	Write Command	MID	254	143	4	192	2	131	D1	chk		
	Response	143	254	MID	4	192	2	131	D1	chk		

Where

MID 8 bit transmitting station identification number, must be 128 or greater.  
 D1 Measurement Filter Time Constant at 0.8 seconds/bit

<b>Tank Capacity &amp; PWM Duty Cycle Parameters</b>	Read Command	MID	254	143	3	192	1	123	chk			
	Write Command	MID	254	143	7	192	5	123	D1	D2	chk	
	Response	143	254	MID	6	193	4	D1	D2	chk		

Where

D1 D2 16 bit Tank volume in gallons, (msb first lsb last)



# SSI Technologies - Application Note AT-AN5

## Acu-Trac™ Ultrasonic Level Sensors

### RS-485 Mode Messaging

<b>Tank Size, Shape, and Measurement Mode</b>	Read Command	MID	254	143	3	192	1	129	chk				
	Write Command	MID	254	143	16	192	14	129	D1	D2	---	D13	chk
	Response	143	254	MID	16	192	14	129	D1	D2	---	D13	chk

Where

- D1 D4 Tank Diameter/Depth 4 byte floating point value in inches, (msb first lsb last)
- D5 D8 Tank air gap 4 byte floating point value in inches, (msb first lsb last)
- D9 D12 Tank width 4 byte floating point value in inches, (msb first lsb last)
- D13 Measurement operation mode selection where,
  - High Nibble Analog output selection 1 = Voltage & 2 = Current loop
  - Low Nibble Measurement mode, 0 = Linear distance, 1 = Cylindrical level & 2 = Rectilinear level

## Timed Broadcasts

<b>Measurement Broadcast</b>	Request	None										
	Broadcast	143	254	14	190	12	D1	D2	---	D12	chk	

Where

- D1 D2 16 bit % of capacity value @ 0.125 % per bit, (msb first lsb last)
- D3 D4 16 bit measurement value, (msb first lsb last)
- D5 D12 8 byte sensor serial number in ASCII

Broadcast Rate,

Message is transmitted 2 times per second.

## Additional References

TIA/EIA – 485-A Electrical Characteristics of Generators and Receivers for Use in Balanced Digital Multipoint Systems. March 1998

SAE J1708 Serial Data Communications Between Microcomputer and Systems in Heavy-Duty Vehicle Applications. October 1993

